

TUFFSTUFF®

AXT-GYM Series



AMERICA'S PREMIER EXERCISE EQUIPMENT

Established 1971

SPECIFICATIONS & WARRANTY

- Space efficient exercise forward design.
- Solid and stable 2 x 4" 11-gauge elevated oval steel main frame.
- Trigger-release device provides quick & convenient press arm adjustments for chest, shoulder and mid-rows exercises.
- Powder coat finish – Ebony Chrome accented with Platinum Sparkle.
- Durable high density pads upholstered in two-tone (Black & Cadet) premium grade, double-stitched naugahyde.
- High density upholstered roller pads.
- USA-Made/Certified 2200 lbs. test 3/16" military-spec nylon coated aircraft style cable.
- Nylon & fiberglass reinforced pulleys with sealed bearings (also available with optional solid aluminum pulleys).
- 3/4" chrome-finish solid steel guide rods.
- Full length protective steel weight shields (except AXT-2).
- 200 lbs. black steel weight plates.

LIFETIME WARRANTY

- AXT-2, 2.5, 3 and 5 used only in a home environment is warranted for **LIFE*** on everything to the original purchaser.

*See Owner's Manual for specific information on warranty, parts, service and labor. Or call 888-884-8275.

NOTICE: TuffStuff continually engages in research related to product improvement. As a result, the product received by the customer may differ slightly from its published description. Improvements in materials, production techniques and design refinements may at any time be introduced into our products. TuffStuff reserves the right to make changes in its product without notice.

EXCLUSIVE FEATURES:



Swivel low row pulley station exclusively for AXT-3 and 5 only.



Built-in beverage holder and hangers for accessory items.



Illustrative exercise flip chart with waterproof clear lamination.



Optional AXT-DLE Leg Developer (seated leg extension/seated leg curl) with patented gravity-latch & thigh-hold down pads.



Optional AXT-SLE Leg Developer (seated leg extension/standing leg curl) with adjustable roller pads.



Steel pulley covers & swivel pulley provide safety and precision alignment.



Trigger-release provides convenient press arm adjustments for chest, shoulder and mid-rows exercises.



Combination cable release and spring loaded plunger makes range of motion adjustments quick & easy.



Standard colors: Black & Cadet superbly crafted "tuck-n-roll" two-tone upholstery.

QUALITY & PERFORMANCE

For nearly four decades TuffStuff has pioneered the development of single and multi-stack home gym systems by focusing on product quality and performance. Many TuffStuff design innovations, mechanical movements and engineering features are patented originals. TuffStuff is committed to improving the lives of its customers by providing quality fitness products and solutions that earn their trust and build lifetime relationships.



TuffStuff Fitness Equipment, Inc.



Exclusive Feature:



Fully adjustable, dual pivot points on the pectoral arms accommodate various arm lengths and helps the user maintain perfect form throughout the full range of motion

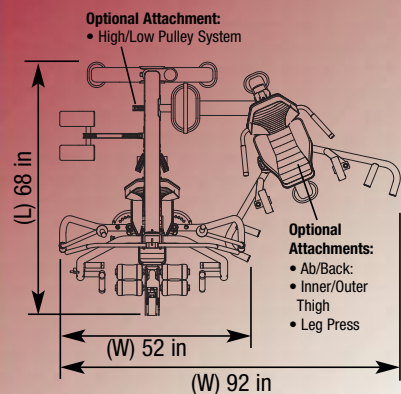

Height: 84 in
Sh Wt: Base Unit 500 lb

Options:

- Ab/Back Attachment
- Inner/Outer Thigh
- High/Low Pulley System
- Leg Press



Shown with optional AXT-DLE Leg Developer

NOTE:
Standard upholstery colors:
Two-tone Black & Cadet

PRODUCT UPGRADE:
Cast iron plates as shown have been changed to black steel weight plates

BASIC EXERCISES

PRESS STATION



- » Chest Press
- » Incline Press
- » Shoulder Press
- » Mid Row

PECTORAL FLY



- » Pectoral Fly

AB STATION



- » Abdominal Crunch
- » Tricep Extension
- » Oblique Twist

LAT STATION



- » Lat Pulldown
- » Tricep Pushdown
- » Reverse Grip Pulldown

LEG DEVELOPER



- » Leg Extension
- » Seated Leg Curl

LOW ROW STATION



- » Standing Arm Curl
- » Upright Row
- » Low Row
- » Inner/Outer Thigh
- » Glute Kick
- » Side Bends



Exclusive Feature:



Features the unique outrigger arms fully adjustable to high, mid and low positions – provides variety and access to unlimited free-style cable movement exercises

Optional Attachments:

- Ab/Back:
- Inner/Outer Thigh
- Leg Press

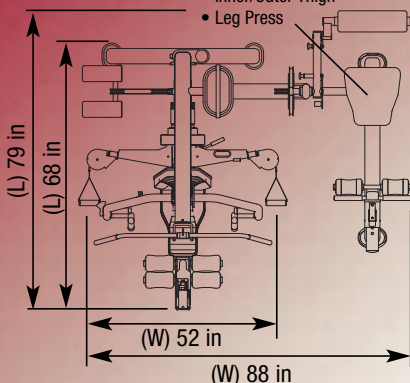

Height: 84 in
Sh Wt: Base Unit 500 lb

Options:







- Ab/Back Attachment
- Inner/Outer Thigh Attachment
- Leg Press Attachment



Shown with optional AXT-DLE Leg Developer

PRODUCT UPGRADE:
Cast iron plates as shown have been changed to black steel weight plates

BASIC EXERCISES

PRESS STATION	OUTRIGGER	AB STATION	LAT STATION	LEG DEVELOPER	LOW ROW STATION
 ▶▶ Chest Press ▶▶ Incline Press ▶▶ Shoulder Press ▶▶ Mid Row	 ▶▶ Pectoral Fly* ▶▶ Chest Press* ▶▶ Incline Press* ▶▶ Shoulder Press* ▶▶ Alternating Press* ▶▶ Seated Curls*	 ▶▶ Abdominal Crunch ▶▶ Tricep Extension ▶▶ Oblique Twist	 ▶▶ Lat Pulldown ▶▶ Tricep Pushdown ▶▶ Reverse Grip Pulldown	 ▶▶ Leg Extension ▶▶ Seated Leg Curl	 ▶▶ Standing Arm Curl ▶▶ Upright Row ▶▶ Low Row ▶▶ Inner/Outer Thigh ▶▶ Glute Kick ▶▶ Side Bends

*Free-style cable movement

AXT 2.5

Exclusive Features:



Fixed position outrigger arms provide variety and access to unlimited free-style cable movement exercises



Easy-to-use gas-assisted seat height adjustment.

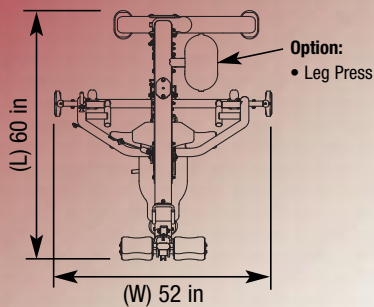

Height: 84 in Sh Wt: 455 lb

Option:

- Leg Press Attachment



BASIC EXERCISES

PRESS STATION



- ▶▶ Chest Press
- ▶▶ Incline Press
- ▶▶ Shoulder Press
- ▶▶ Mid Row

OUTRIGGER



- ▶▶ Pectoral Fly*
- ▶▶ Chest Press*
- ▶▶ Incline Press*
- ▶▶ Shoulder Press*
- ▶▶ Alternating Press*

*Free-style cable movement

AB STATION



- ▶▶ Abdominal Crunch
- ▶▶ Tricep Extension
- ▶▶ Oblique Twist

LAT STATION



- ▶▶ Lat Pulldown
- ▶▶ Tricep Pushdown
- ▶▶ Reverse Grip Pulldown

LEG DEVELOPER



- ▶▶ Leg Extension
- ▶▶ Standing Leg Curl

LOW ROW STATION



- ▶▶ Standing Arm Curl
- ▶▶ Upright Row
- ▶▶ Low Row
- ▶▶ Inner/Outer Thigh
- ▶▶ Glute Kick
- ▶▶ Side Bends



Exclusive Features:



Fully adjustable leg developer accommodates various leg lengths



Easy-to-use gas-assisted seat height adjustment.

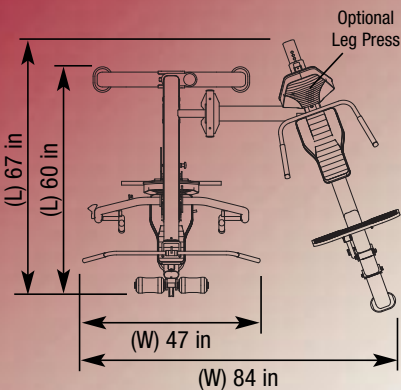

Height: 84 in
Sh Wt: Basic Unit 405 lb

Option:

- Leg Press Attachment



NOTE:
Standard upholstery colors:
Two-tone Black & Cadet

PRODUCT UPGRADE:
Cast iron plates as shown have
been changed to black
steel weight plates

BASIC EXERCISES

PRESS STATION



- » Chest Press
- » Incline Press
- » Shoulder Press
- » Mid Row

AB STATION



- » Abdominal Crunch
- » Tricep Extension
- » Oblique Twist

LAT STATION



- » Lat Pulldown
- » Tricep Pushdown
- » Reverse Grip Pulldown

LEG DEVELOPER



- » Leg Extension
- » Standing Leg Curl

LOW ROW STATION



- » Standing Arm Curl
- » Upright Row
- » Low Row
- » Inner/Outer Thigh
- » Glute Kick
- » Side Bends



Base Unit With Single Station Attachment

DIMENSIONS (inches): (W) – Width (L) – Length	(W) Ab/Back	(L) Ab/Back	(W) Inner/Outer	(L) inner/Outer	(W) High/Low	(L) High/Low	(W) Leg Press	(L) Leg Press
	AXT-2 Base Unit							84
AXT-2.5 Base Unit							84	67
AXT-3 Base Unit	88	79	95	68			88	75
AXT-5 Base Unit	87	77	92	68	57	68	85	75



Ab/Back



Inner/Outer Thigh



Leg Press



High/Low Pulley System



IMPORTANT NOTE:

Standard upholstery colors Black & Cadet on all optional attachments.

OPTIONAL EXERCISES

AB/BACK



- ▶▶ Abdominal Crunch
- ▶▶ Back Extension

INNER/OUTER THIGH



- ▶▶ Seated Inner Thigh
- ▶▶ Seated Outer Thigh

LEG PRESS



- ▶▶ Leg Press
- ▶▶ Calf Raise

HIGH/LOW PULLEY



Functional cable exercises
(single or dual arm movements)

- ▶▶ Tricep Extension
- ▶▶ Tricep Pushdown
- ▶▶ Lat Pulldown
- ▶▶ Ab Crunch
- ▶▶ Mid Row
- ▶▶ Chest Fly
- ▶▶ Rear Delt
- ▶▶ Standing Arm Curl
- ▶▶ Upright Row
- ▶▶ Deltoid Raise
- ▶▶ Low Row
- ▶▶ Inner/Outer Thigh
- ▶▶ Glute Kick
- ▶▶ Side Bends



TuffStuff Fitness Equipment, Inc. 1325 E. Franklin Avenue, Pomona, CA 91766, USA
Ph 909-629-1600 Fx 909-6290-4967 info@tuffstuff.net

www.tuffstufffitness.com